

PLS



30 RT

SUPERSTRUCTURE SPECIFICATION

Superstructure

Welded steel fabricated frame on which the telescopic jib, winch, slewing unit, derricking cylinders, counterweight and operator's cab are mounted. The superstructure is capable of continuous slewing in either direction and rotates on a slew bearing. A central hydraulic & pneumatic rotary joint and electrical slip ring assembly are provided between superstructure and chassis.

Boom

Construction - 3 section fully powered boom made from high tensile steel.

Telescoping - Fully synchronized boom extending from 9.9 m to 24.5 m using cylinder and chain retraction and automatic load holding.

Derricking - Double acting hydraulic cylinder fitted with Integral pilot operated counter balance safety check valve.

Boom Angle - 0° to 80°

Derricking Speed - 45 sec

Slew System

Hydraulic motor driven planetary reduction unit with slew pinion provides 360° continuous slew in either direction. Counter balance valve incorporated for smooth jerk free braking.

Brake - Spring applied, hydraulically released multi-plate brake.

Slew Speed - Maximum 2.8 rpm.

Slew Ring - Internal teeth slew ring grease packed and sealed for long life. Mounted on precision machined surface to prevent distortion of the slew ring.

Hoist System

It is driven by a hydraulic motor through a planetary gear reduction unit for hoisting. Counter balance valve provided for controlled lowering. It has fail safe multi disk brakes released hydraulically. Hoist drum with grooves, 18 mm wire rope. Overlowering switch provided with hydraulic cut-off.

Hoist Brake - Spring applied, hydraulically released multi-plate brake.

Line speed - 60 m/min

Operator's Cabin

Steel frame construction with lockable sliding door to permit easy access. Large glazed areas with rear opening windows allow maximum all round vision. Ergonomically positioned joystick levers on either side of seat control all craning motions. Instrumentation located on console in front of operator. Seat is adjustable. All windows are fitted with toughened glass and lockable sliding door. Cabin is fitted with interior light, electric wiper on the windscreen, electric horn and fan. Slew locking arrangement is controlled from inside the cabin.

Crane Controls

Joystick controls for slew, telescoping, hoisting and derricking with independent or simultaneous operation.

Control Valves

All control valves mounted on side of superstructure offering easy accessibility. Load sensing, load sharing control valves operated by joystick control levers from operator's cab. Electro hydraulic solenoid valves control hydraulic outriggers.

Instrumentation

Audible and visual warning for engine and torque converter temperature and air pressure, alternator, parking brake, directional indicators, air pressure gauge and engine hour meter gauge.

Safety System

Load Moment Indicator - Microcontroller based LMI is fitted on the crane along with angle & length sensors. Display / CPU is mounted inside the operator's cab. Indicator for load, safe working load, radius, boom angle, boom length and % SWL margin are available on the display unit. Audio visual warnings for approach, overload, overhoist, rope break are provided. In case of overload hydraulic cut-off is activated by the LMI.

Other Safety Features - Load holding lock valves on cylinders for protection against hose burst or power failure. Motion control overcentre valves for smooth movement of loads.

Electricals - 24 Volts negative earth.

Optional Equipments

- Four part Boom (10.10 - 32.00 m)
- Fly jib, 7.6 m, fixed
- Offsetable fly jib 8 m, 0 - 15 - 30°
- 5T, 1/2 hook block
- 3T, single line pear weight
- 3T, Aux. hoist winch
- Cab heater
- Cab AC
- Spare wheel / tyre
- Man carrying basket
- Flood light
- Dual speed winch

Too Kit

Standard maintenance tool kit.

CARRIER SPECIFICATION

Chassis

High grade steel, welded box type, torsion resistant structure with outrigger boxes.

Drive

4 x 4 / 4 x 2 wheel drive with four wheelsteer.

Outriggers

Four hydraulically operated telescopic outrigger beams with vertical hydraulic jacks fitted with hydraulic lock valves. Vertical jacks fitted with removable, stowable outrigger feet. Outrigger controls located in operator's cab. Independent control for outriggers with individual beam and jack operation.

Engine

Suitable diesel engine of adequate horsepower.

Transmission

Remote mounted torque converter driving full power shift transmission with 6 forward and 6 reverse speeds.

Fuel Tank

Fabricated tank with an oil capacity of 205 litres.

Hydraulic Pump

Multiple pumps driven from transmission, provide flow to the hydraulic system.

Hydraulic System

All crane operations are hydraulically controlled through pilot pressure available from hydraulic joystick valves. Outriggers are operated through electro-hydraulic valves. Pressure relief valves are provided to protect the pumps and hydraulic system components. Motion control valves / lock valves provide smooth crane operations.

Hydraulic Tank

Fabricated tank with an oil capacity of 460 litres.

Front Axle

Drive / steer axle with hydraulic disc brakes and planetary wheel hubs, axle rigidly mounted to frame.

Rear Axle

Drive / steer axle with air actuated DCDL, hydraulic disc brakes and planetary wheel hubs, axle oscillation locking through hydraulic cylinders.

Steering

Front - Hydraulically powered steering controlled by steering wheel.

Rear - Hydraulically powered steering with rear wheel steering indicator. Positive lock to hold in center line rear wheel for road travel.

Brakes

Service - Two line braking system, air over hydraulic foot operated on all wheels.

Parking - Spring applied and hydraulically released on front and rear axle.

Wheel Tyres

18.00 x 25 with earthmover tread pattern.

Max. Speed - 30 kmph

Max. Gradeability - 50%

Weight Distribution

Front - 13400 Kgs

Rear - 14800 Kgs

GVW - 28200 Kgs

GENERAL DIMENSIONS

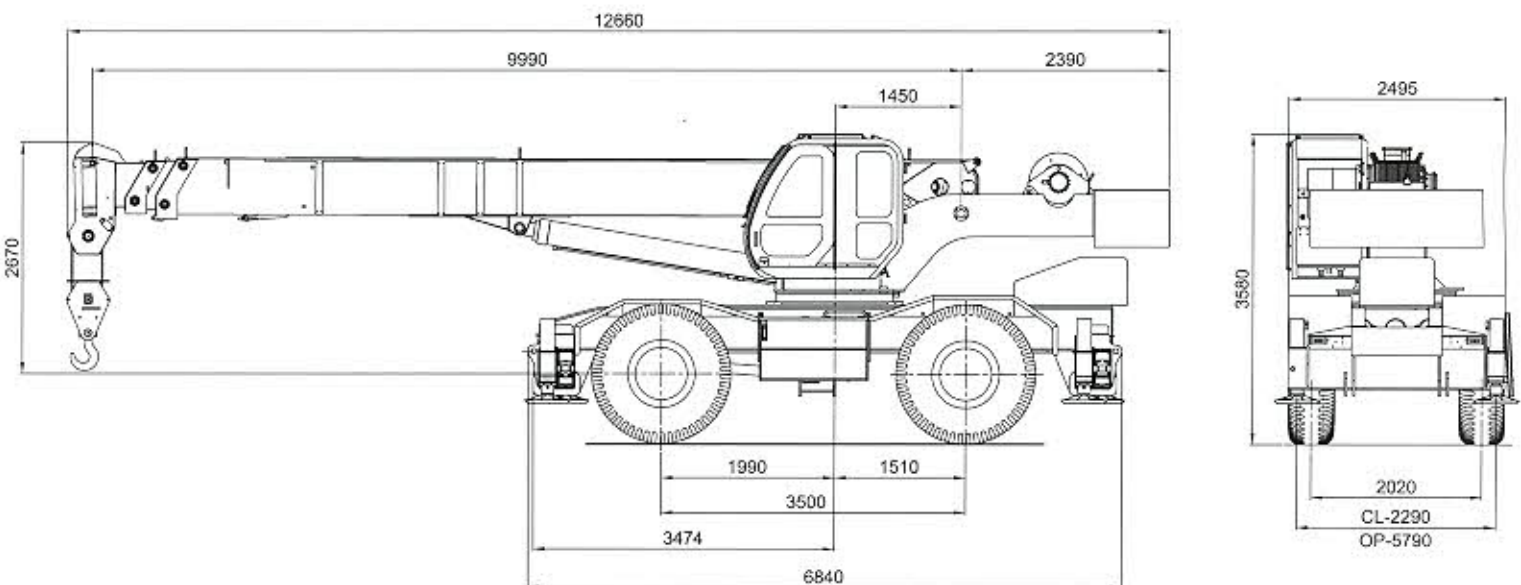

LOAD CHART

RADIUS	CAPACITIES ON OUTRIGGERS - 360° (85%)							FREE ON WHEEL CAPACITIES (85%)			
	BOOM LENGTH (m)							9.90 m		12.00 m	
	9.90	12.00	14.00	16.00	18.00	20.00	24.50	360° STATIC	OVER FRONT 5 kmph	360° STATIC	OVER FRONT 5 kmph
m	Kg	Kg	Kg	Kg	Kg	Kg	Kg	Kg	Kg	Kg	Kg
3.0	30,000	21,778	21,349	20,921	19,549	16,805		12,432	14,576		
3.5	25,465	21,778	21,349	20,921	18,177	15,690		10,718	12,861		
4.0	23,664	21,778	21,349	20,921	17,234	15,005		9,174	12,004		
4.5	21,435	20,921	20,921	18,177	15,862	13,461		6,859	10,460		
5.0	18,691	18,691	18,691	17,748	14,576	12,261	10,460	6,002	9,431		
6.0	15,005	15,005	15,005	14,233	12,261	10,889	8,660	5,144	7,717		
7.0	12,261	12,261	12,261	12,261	10,460	9,088	7,631	3,430	7,031		
8.0		9,088	9,088	9,088	9,088	8,145	6,688			3,001	6,002
9.0		7,459	7,459	7,459	7,459	7,288	5,830			1,715	4,716
10.0		6,431	6,431	6,431	6,431	6,431	5,487			1,371	3,858
11.0			5,659	5,659	5,659	5,659	4,801				
12.0			4,801	4,801	4,801	4,801	4,544				
13.0				4,287	4,287	4,287	4,287				
14.0				3,687	3,687	3,687	3,687				
15.0					3,430	3,430	3,430				
16.0					2,915	2,915	2,915				
17.0						3,100	3,100				
18.0						2,700	2,700				
19.0							2,400				
20.0							2,200				
21.0							1,900				
22.0							1,800				

Notes:

- ☐ Lifting capacities are based on 85% duty as per IS 4573.
- ☐ Lifting capacities at max radius is based on boom angle not less than 15°.
- ☐ Weight of slings, hook block or any lifting device must be added to the load being lifted.
- ☐ In blocked condition, outriggers are fully extended and vertical jacks supported on firm ground with tyres lifted off the ground and chassis is levelled.
- ☐ When performing crane duties in F.O.W. conditions, it must be ensured that all tyres are filled to specified air pressure and floating axle is locked.
- ☐ Crane should not be operated during high wind conditions which affect stability.
- ☐ For over front capacity on wheels, boom must remain within +/- 5° from the longitudinal axis of the vehicle.
- ☐ The jib can be telescoped in/ out with the load suspended, provided it is within the capacity as per the load chart.
- ☐ With fly jib in erected condition, the main boom capacities shall be reduced by 700 kgs.
- ☐ If the hook block is fitted to the main boom, the fly jib capacities must be reduced by the weight of the hook block of the boom.
- ☐ Proper duty must be selected in the safe load system before lifting the loads.
- ☐ All dimensions are within ±5%.

HEIGHT & LIFT

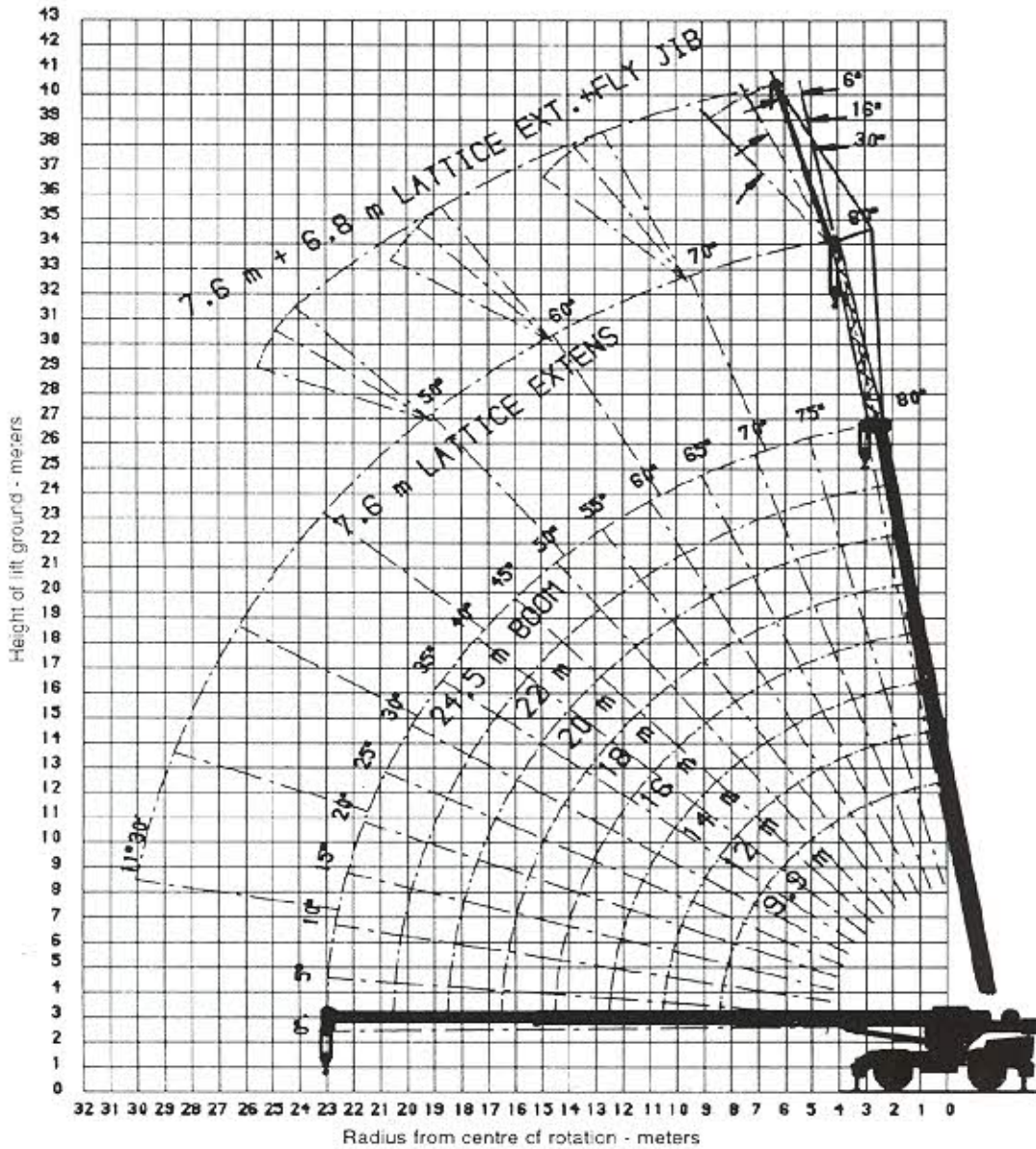

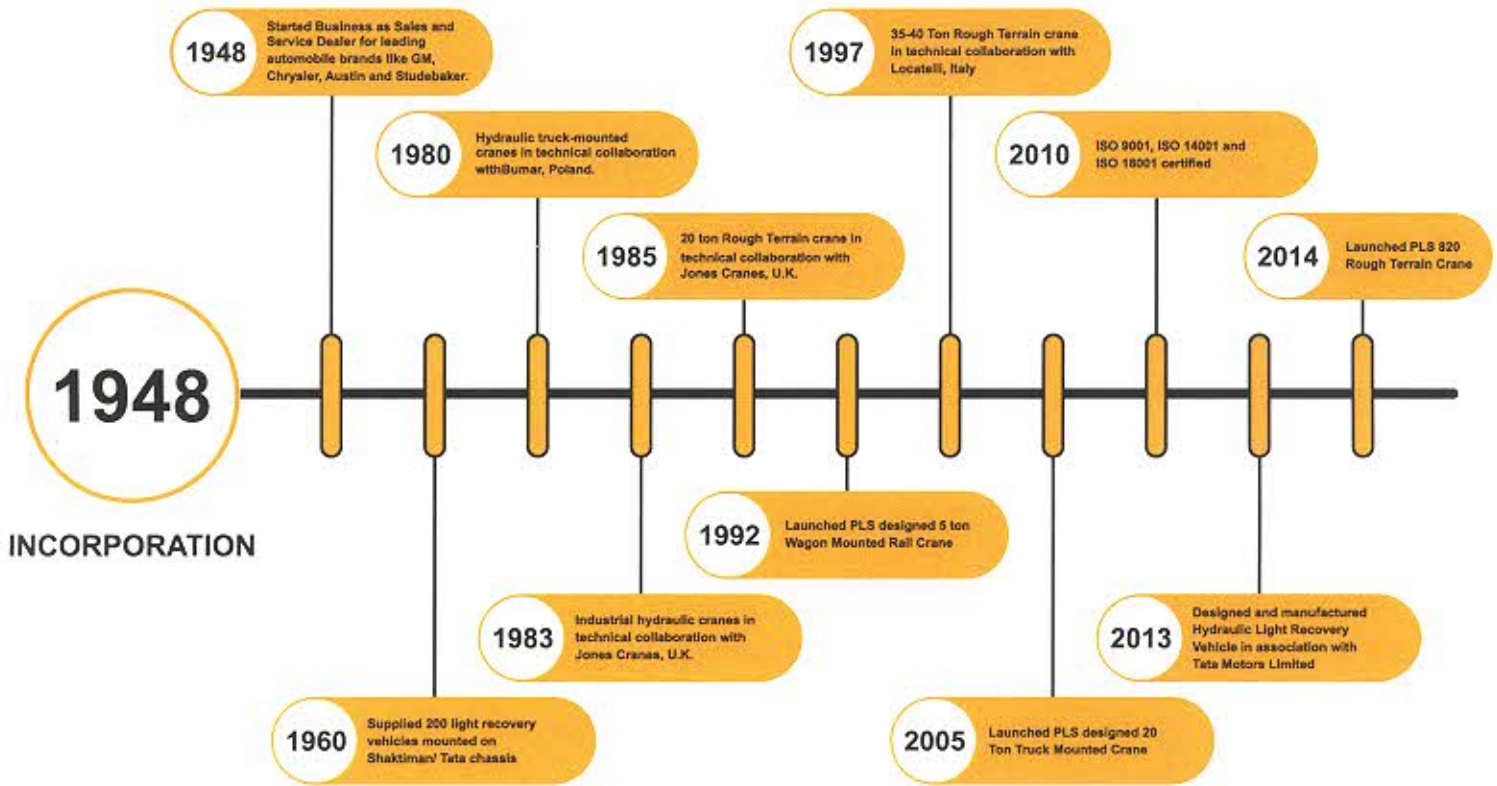

Pearey Lall & Sons (E.P.) Ltd, (PLS) is a renowned name in the Crane Industry. Cranes manufactured at PLS are designed keeping in mind the state-of-the-art technology and engineering excellence.

Through years of experience and various collaborations, PLS has offered a variety of well-designed solutions for diverse challenges in material handling. We manufacture cranes that meet the required quality, safety and operational standards.

ISO 9001
Quality Management Systems

ISO 14001
Environment Management Systems

ISO 18001
Occupational Health and Safety Advisory Services



Our Service Centers

- Jodhpur
- Mumbai
- Kolkata
- Chandigarh
- Vishakhapatnam
- Kochin
- Guwahati

Pearey Lall & Sons (E.P.) Ltd.

Works

9th Milestone, G. T. Road, Sahibabad,
Ghaziabad 201007, U.P.
Phone: +91 120 417 7900 / 7907
Fax: +91 120 4177991
Email: sales@plseindia.com

www.plsindia.com

